

January 2022

## Villa Del Mar Homeowners Association

# The Script

### Inside this Issue

**Pg. 1** Christmas Tree Pick Up

**Pg. 1** Unit Improvements

**Pg. 2** EJ Harrison Food Waste  
New Law

**Pg. 2** Gas Shut-Off Valves

**Pg. 2** Patio Drains, Gutters and  
Downspouts

**Pg. 2** Monthly Reminders

**Pg. 2** Important Days in January

Villa Del Mar Homeowners Assoc.  
1055 Palmetto Way  
Carpinteria, CA 93013  
(805) 684-7430  
Email: [villadelmar@verizon.net](mailto:villadelmar@verizon.net)  
Website: [villadelmarhoa.com](http://villadelmarhoa.com)  
Rebecca Barnhardt, CMCA, AMS:  
Manager

### Christmas Tree Pick Up *Recycling of Trees*

We will be picking up trees and utilizing them for our landscaping material needs.

**For your convenience our Villa Del Mar staff will pick up your tree on one day only.  
January 5th between 8-9 am**

Place your tree where you would normally place your bins on Wednesday January 5<sup>th</sup>. It is that simple and convenient.



Please make sure that you have removed all ornaments from your tree. Make sure to remove your tree stands and skirts. Trees must also be free of all tensile as to avoid damaging cutting equipment. Trees will not be picked up if they still have any of these items on them. Flock trees will be accepted this year.

If you have any questions please contact the office at (805) 684-7430.

### Unit Improvements *Unit Work Requires Approval*

Please remember when making home improvements most changes require prior Board approval. Also alterations which effect exterior esthetics, such as windows and front & screen doors, satellite dishes and water softeners have set specifications they must meet

before they can be approved. Homeowner requests are reviewed and may need to be submitted to the Board for final approval.

You may make requests on the VDM website under Resident Resources tab at:

[www.villadelmarhoa.com](http://www.villadelmarhoa.com) or by email or mail. All requests should include the following information:

1. Unit number, homeowner name and contact information.
2. Identify the change to be made and their location at your unit address.
3. Attach brochures, pictures (if available) or drawings of proposed product plans.
4. List installing contractor, their contact information and contractor's license number.

On certain items the office can give you permission to move forward with your project, however in some

instances further information and approvals may be required. Make sure that the person or company doing the work has up-to-date insurance and is bonded. You can look up contractor’s licenses to make sure they are current by going to: <https://www.cslb.ca.gov/>

### ***EJ Harrison Food Waste New Law No Changes at this Time***

EJ Harrison recently sent out notices regarding the new food waste law and changes to trash pick-up. Although they are working on a food waste system, there is no solution at this time. We are asked to dispose of food waste in trash cans as you have been previously doing. There is no easy solution to the collection of food waste in our community and we will be notified

if this changes. EJ Harrison is working with third party contractors to find ways to implement the new laws and we will let you know of any future impacts.

### **Gas Shut-Off Valves *No Gas-What Should You Do***

In light of our risk of earthquakes in Southern California, we installed emergency gas shut off valves a few years ago. Sometimes those valves can also be tripped by construction work or landscaping activities. If your gas is off you should try calling the office first. We will send a crew member by to check on the earthquake

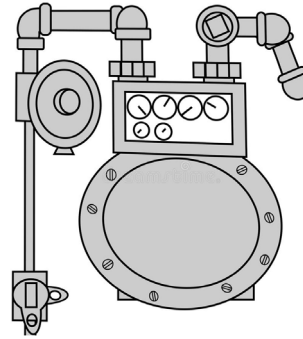

emergency shut off valve. If it is after hours you may reach out to our emergency phone by calling (805) 220-0173.

The emergency shut off valves will also shut off in the case of an earthquake 5.4 magnitude or greater. This was done to prevent fire breakouts. In a major earthquake, fires cause the most amount of property damage.

If you call the gas company they will charge a hefty service fee and this is a simple reset. Call the office at (805) 684-7430 for more information.

### **Patio Drains, Gutters and Downspouts**

#### ***Please Report Issues***

Patio drains in every patio are for the purpose of preventing your unit from being flooded. Please make sure to locate them and keep patio drains clear of plants & roots, dirt, pots, debris and patio items. The Association is only responsible for the main drainpipe and not any connecting pipes. Most patio drains are located on each side of the cement entry from the gate about 18 inches to 24 inches from the cement walkway edge.

If you have a clogged or damaged gutter report to the office right away. Staff can’t get on ladders when it is raining or windy. Your help is appreciated.

# ***Monthly Reminders***

**Street Sweeping Day:** REMINDER: **NO PARKING** in the alleys and Driveways at VDM during this time. Street sweeping day is the **3<sup>rd</sup> Wednesday of every month.** This month it is **Wednesday, January 19, 2021.** Please do not park on the city streets between 8:00am - 10:00am. The City will issue parking tickets which are about \$45.

**General Board Meeting:** There will not be a General Board Meeting in January.

**Important Days in January:** January 12<sup>th</sup> – National Hot Tea Day, January 17<sup>th</sup> – Martin Luther King Jr. Day, January 23<sup>rd</sup>- National Pie Day.

